

S20G Low headroom hoist/geared trolley combination



These low headroom hoist-trolley combinations are only supplied with REMA Select 200OD hand chain hoist.

Properties

- Low headroom.
- Operating with hand chain.
- Technical detail hand chain hoist, see Select 200OD.
- Tilting and anti-drop protection for additional safety.
- Suitable for attachment to various I-beams and H-beams.

Standard delivery

- Including hand operated trolley.
- 3 meters lifting height.
- 2.5 m operating height.

Option

- Any other hoisting height and operating height is also possible.

Norm:

- EN12100-1/2, EN13157, EN818-7

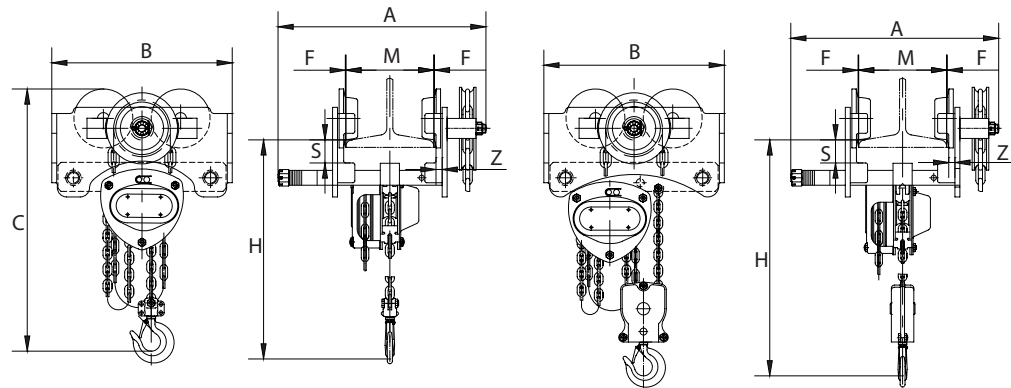

single fall

double fall

Type	WLL (kg)	Number of falls	Flange width (mm)	Min. radius (mm)	Load chain (mm)	Operating chain (mm)	Weight (kg)		ProductId
S20G/200OD-0.5	500	1	50-203	800	5,0 x 15,0	5.0 x 23.7	55	19.0	0931001
S20G/200OD-1.0	1.000	1	64-305	900	6,3 x 19,1	5.0 x 23.7	68	27.0	0931003
S20G/200OD-1.5	1.500	1	74-305	1000	7,1 x 21,0	5.0 x 23.7	80	39.0	0931005
S20G/200OD-2.0	2.000	1	88-305	1000	8,0 x 24,0	5.0 x 23.7	80	49.0	0931007
S20G/200OD-3.0	3.000	2	100-305	1200	7,1 x 21,0	5.0 x 23.7	100	67.0	0931009
S20G/200OD-5.0	5.000	2	114-305	1300	9,0 x 27,0	5.0 x 23.7	110	92.0	0931011

Type	A (mm)	B (mm)	Cmin (mm)	F (mm)	Hmin (mm)	M (mm)	S (mm)	Z (mm)
S20G/200OD-0.5	322	258	310.5	1.5~3	243.5	50-203	30	9
S20G/200OD-1.0	435	292	420	1.5~3	340	64-305	37	8
S20G/200OD-1.5	433	360	460	1.5~3	380	74-305	39	10
S20G/200OD-2.0	446	360	500	1.5~3	405	88-305	38	10
S20G/200OD-3.0	459	430	590	1.5~3	475	100-305	42	12
S20G/200OD-5.0	474	447	725	1.5~3	610	114-305	41.5	16